



Metal detector&Check weigher

CW-1.2K

User's manual

(Applicable for MCGS+C01 version)

杰·曼·科·技

531701010040 Ver A0

Contents

1.	Summary	1
	1.1.1 Mechanical part	2
	1.1.2 Electrical part	2
1.2	Usage Notice	2
	1.2.1 Precautions	2
2.	Product installation	4
2.1	Overall appearance	4
2.2	Mechanical installation	6
2.3	Electrical installation	6
2.4	Electrical interface	8
2.5	Power supply power	10
3.	Operation	12
3.1	Operation summary	12
3.2	Limit removal	12
3.3	Basic operation	13
	3.3.1 Power-on operation	13
	3.3.2 Zero clear operation	14
	3.3.3 Start up operation	14
	3.3.4 Stop operation.....	15
	3.3.5 Power off operation	15

3.4	User login	15
3.5	Product selection with New	16
3.5.1	Select product parameters	16
3.5.2	New product parameters.....	16
3.5.3	Modify product parameters	20
3.5.4	Delete product parameters.....	21
3.6	Calibration scale	21
3.6.1	The weight calibration scale	22
3.6.2	Dynamic calibration of scale	23
4.	Data viewing	26
4.1	Check the result data	26
4.2	Statistics	27
4.3	Alarm information	27
4.4	Statistical graph.....	28
5.	Quantity of switches	29
5.1	I/O I/O testing.....	29
6.	Working parameters	34
6.1	Working parameter Settings.....	34
7.	Communication.....	39
7.1	Communication parameters	39
7.1.1	Serial port communication.....	41

7.1.2	Network port communication.....	41
7.1.3	MAC address	42
7.2	The Modbus register communication address is defined	42
7.3	Print content	48
7.4	Set the parameters of the driver	50
8.	Program upgrade	51
9.	Metal Detection Guide.....	52
9.3.1.1	Product number	53
10.	Size	62
10.1	Outline size drawing (unit: mm)	63
11.	Equipment repair and maintenance	65
11.1	Maintenance of motors.....	65
11.1.1	Routine maintenance	65
11.1.2	Regular maintenance	65
11.1.3	Precautions	65
11.2	Check the failure cause and treatment method of weight scale....	65
11.2.1	No display on the touch screen.....	65
11.2.2	Data pulsation large, abnormal fluctuation	65
11.2.3	The display is always zero.....	66
11.2.4	Abnormal data display	66
11.2.5	Busy alarm.....	66

11.2.6	Packaging error	66
11.2.7	Continuous nonconformity alarm	67
11.2.8	Excess plugging time	67
11.2.9	Below the minimum sampling time	67
11.2.10	Super maximum sampling time.....	67
11.2.11	Overload motor load limit.....	67
11.2.12	Automatic zeroing failed.....	67

Shenzhen General Measure Technology Co., Ltd. All rights reserved.

Without the permission of Shenzhen Geman Technology Co., LTD., no unit or individual may copy, disseminate, transcribe or translate into other language versions in any form or by any means.

Due to the continuous improvement and update of our products, we reserve the right to modify this manual at any time without prior notice. For this purpose, please visit our website frequently for timely information.

The company's Web address <http://www.gmweighing.com>

1. Summary

CW-1.2K metal detector and weighing integrated machine is an industrial metal detection and weighing integrated equipment developed by our company to meet the ever-changing technological updates with high speed, high precision, small range, and metal detection function.

The full touch screen makes the CW-1.2K metal detector and weighing integrated machine easy to operate, and the external expansion of IO input and output ports and external serial port network communication achieve multi-point control, monitoring, and remote control of the product. Product Features

Product parameters;

Model number	CW-1.2K
Power Supply	AC220V±10%, 50/60Hz, 400W
Weighing range	100 to 1200g
Accuracy of weight inspection	Plus or minus 0.7 g
Weight checking speed	≤100 pieces/min
Size of object to be measured	Length: 50~300mm Width: 20~220mm Height: 10~100mm
Conveyor belt speed	5 to 40 m/min
Belt size	400mm*250mm
Metal detection sensitivity	Fe≥φ0.8mm Sus304≥φ2.0mm Non-Fe≥φ1.5mm
Effective width of metal detector	250mm
Effective height of gold inspection	100mm
Center distance of drum shaft	400mm
Countertop height	750 (±50mm) (customizable)
Operating temperature	0 to 40°C

Maximum humidity	90% R.H non-dew forming
Ultimate load	The instantaneous ultimate load shall not exceed 2.4kg

Note: Scale stands are strictly prohibited from being used over the range. The sensitivity of metal detector is related to the characteristics of the product being tested (such as humidity, temperature, salt content, mineral content, etc.), and there are also some environmental impacts, such as vibration, electromagnetic field interference, etc., that can affect the actual detection sensitivity of the equipment.

1.1.1 Mechanical part

1. Electric control box is small and movable, easy to install and operate on site.
2. The servo driver is used as the motor driving device to ensure the speed stability and adjustability in the process of weight checking.
3. Double photoelectric mode more accurately determine the object up and down the weighing platform, improve the accuracy and efficiency of weight detection.
4. The height adjustment range of the weighing table is larger, which is convenient for customers to choose and use.
5. The mechanical modular design makes transportation and maintenance more convenient, and the application adaptability stronger.

1.1.2 Electrical part

- 1.Simple wiring, external only need to access the power cord;The internal use of different specifications pin plug terminal block, wiring is convenient and will not make mistakes.
- 2.Touch screen operation interface optimization, product parameter setting is simple and the main interface content is richer.
- 3.The three-color indicator shows qualified (green), out-of-tolerance (red), undertolerance (yellow), and the working state of the inspection weight is clear at a glance.Buzzer user can define the alarm mode.
- 4.The new algorithm is adopted in the process of weight inspection, and the high precision can be guaranteed in the process of high-speed weighing.
- 5.Optimize user login and logout function, without tedious operation and effectively prevent others from misoperation.

1.2 Usage Notice

1.2.1 Precautions

- 1.Do not perform mechanical or electrical maintenance while live, do not place tools on the scale, and do not perform welding operations on the scale.
- 2.The installation site must ensure the ground level, after installation through the foundation adjustment, ensure that the weighing table level, tilt does not exceed 0.5 degrees, away from the vibration source.
- 3.Make sure the equipment is safely grounded and there is no strong electricity or

magnetic field interference nearby.

4. Do a good job of fire prevention, avoid direct sunlight to check the weighing table and relatively strong air flow (outdoor air, fan and air conditioning outlet is directly against the weighing table).

5. Should avoid squeezing, stepping on the scale platform, handling should first fixed scale, installed sensor limit to prevent damage to the sensor, prohibit the direct handling of the scale platform to move.

2. Product installation

2.1 Overall appearance

The product appearance is shown in Figure 2-1 below.

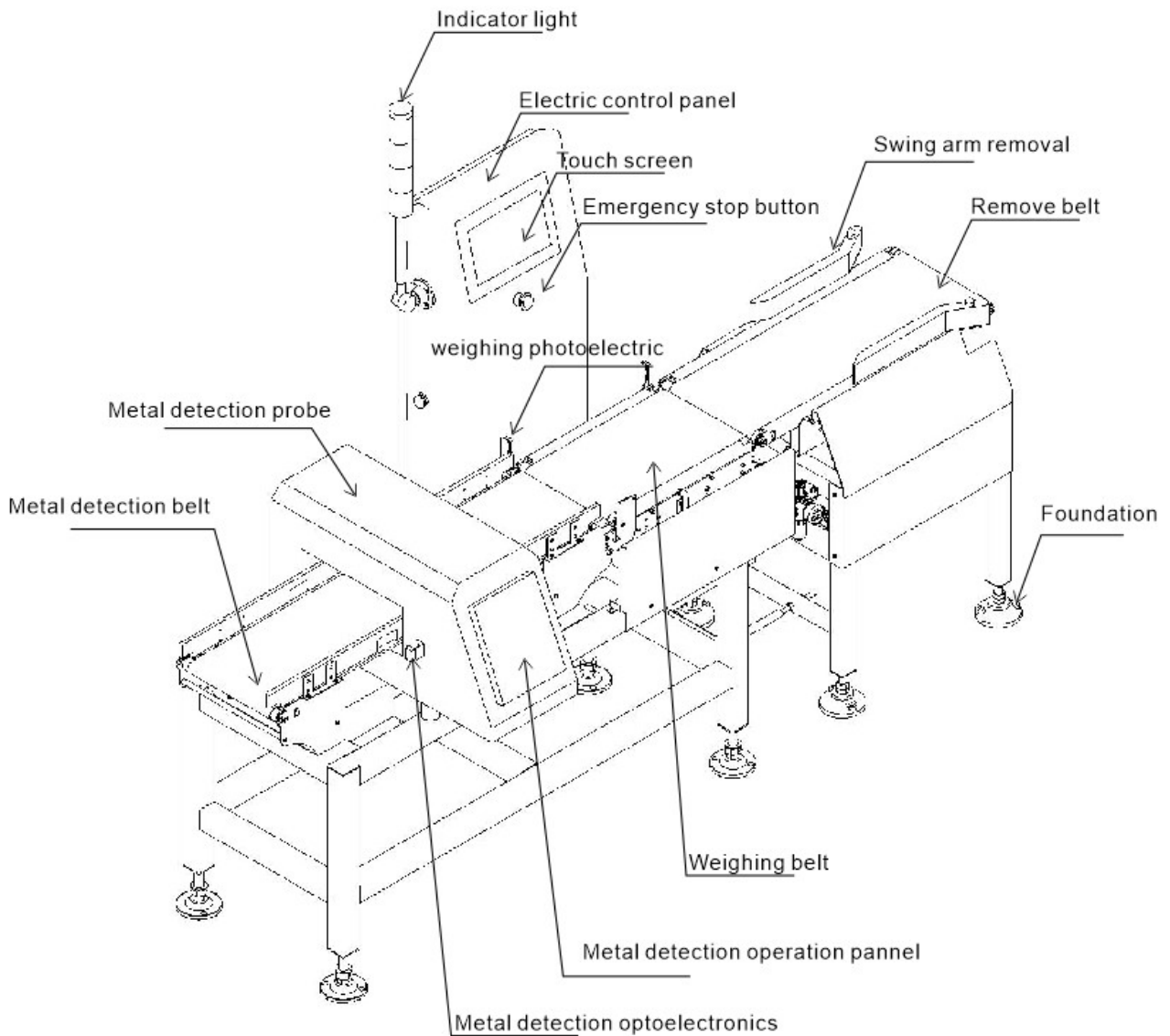

Figure 2-1 Overall appearance of the product

Serial number	Name	Introduction
1	Indicator light	A more intuitive display of the test results, so that the distance can also see the results of the state.
2	Conveyor belt	The conveying end of the weighing platform on the object
3	Electric control panel	Control the weight inspection process and connect external devices
4	indicator light	More intuitive display of the weight inspection results, allowing the status of the results to be seen from a distance.
5	Emergency stop button	Emergency stop
6	touch screen	View display data and set product parameters
7	Weighing photoelectric sensor	Judge the weight table of the object up and down
8	Metal detector photoelectric sensor	Determine whether an object has entered the metal detector probe
9	Weighing belt	The conveying end for weighing objects
10	Remove the end belt	Unqualified products will be eliminated at this location
11	Swing arm removal	Arm swinging method for elimination
12	Metal detector	Perform metal detector on objects and output detection results
13	Metal detector control panel	Viewing Display Data and Setting Product Parameters (Metal Testing)

2.2 Mechanical installation

Place the weighing scale at the installation place and remove the sensor protection device; Adjust the levelness of the weighing scale, and the inclination shall not exceed 0.5 degree; Fix the footing of the weighing scale, the stainless steel footing contacts the ground smoothly, and lock the screws of the footing to ensure the stability of the weighing scale.

Adjust the distance between the check weighing platform and the front and rear end conveying mechanism is 9 ~ 11mm, and the check weighing platform shall not be in contact with other equipment. If the front and back end conveying mechanism is not equal to the height, it is necessary to add the oblique conveying mechanism on one side, and add the horizontal conveying mechanism connection on the side of the oblique mechanism (to leave a gap) to check the weight scale platform, to ensure that the check weight scale platform level and the height of the front and back end conveying mechanism.

The electric control box can be arbitrarily installed on the left and right sides of the weighing scale to facilitate the operation of the production process.

2.3 Electrical installation

The power supply is inserted into the three-hole socket with ground or connected to the power supply equipment such as the electric gas cabinet according to the line mark. The metal detection rejection signal and the photoelectric signal of the metal detection machine have been connected to the weighing controller, and the metal detection part does not require external wiring.

1. Any wiring and disconnecting operation can only be carried out after power off. After the operation is completed, check before power on.
2. The serial port is fixed to RS485 communication, where the 485(A) pair should be connected to 485(A) or 485(+), and the 485(B) pair should be connected to 485(B) or 485(-).
3. The switching quantity input point is valid at low level (DC0V) and does not allow access to high voltage or alternating current.
4. Switching quantity output point access relay coil for intermediate control, so the other end of the relay can access DC or AC power supply switching quantity.

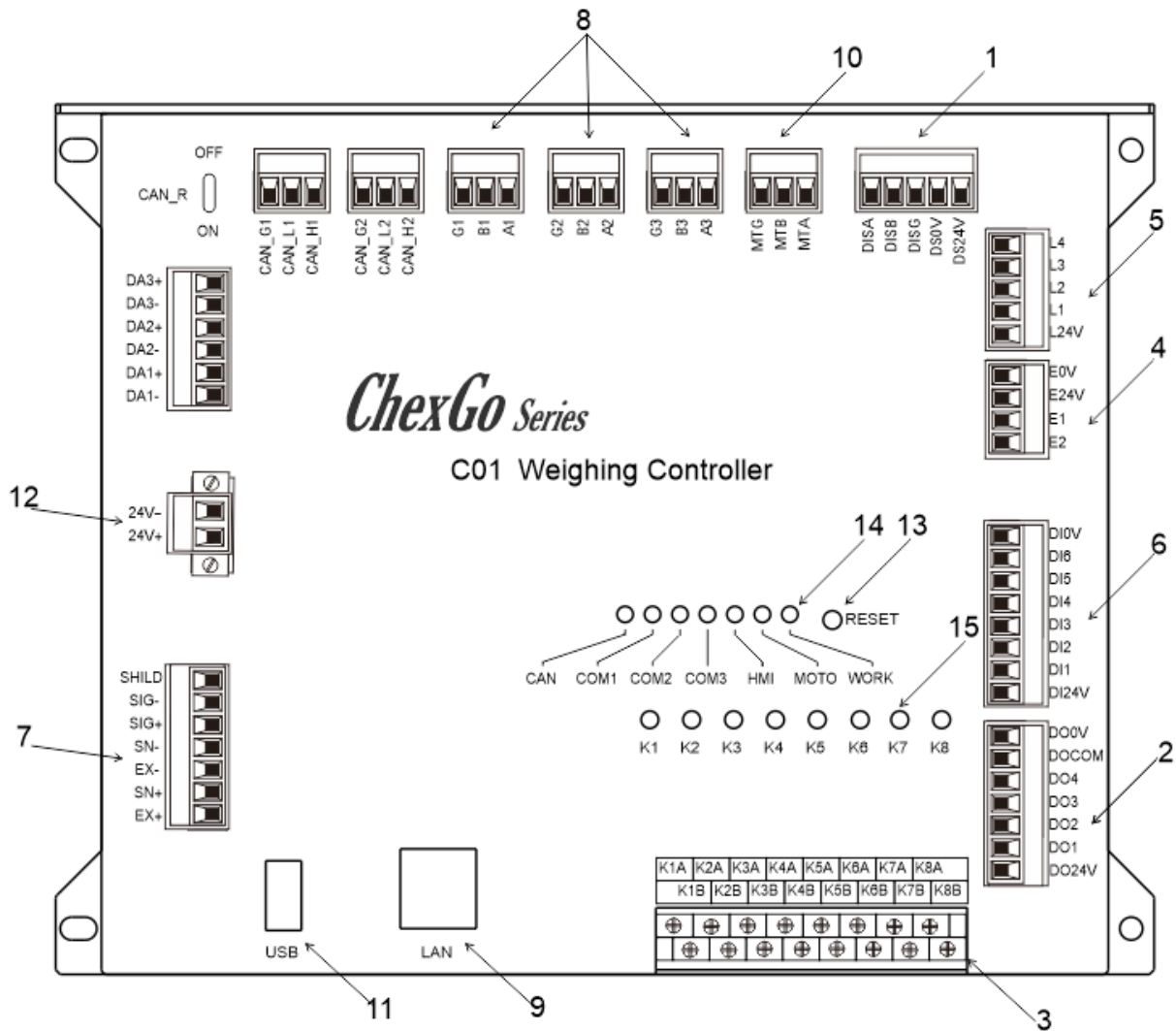

Figure 2-2 Control panel of weighing scale

Serial number	Function
1	Touch screen communication jack
2	External custom outlet OUT1-OUT4
3	External custom output relay K1-K8
4	Detect the photoelectric sensor wiring terminals
5	Alarm light wiring terminals
6	Custom input ports 1-6 externally

7	Sensor terminal
8	External RS-485 communication jack
9	External TCP/IP communication network port
10	Inverter communication jack
11	External USB data interface
12	24V power terminal
13	Reset key
14	Communication status indicator
15	Output relay status indicator light

2.4 Electrical interface

Photoelectric sensor (already wired at factory) :

E24V: photoelectric sensor DC24V+.

E0V: photoelectric sensor DC24V-.

E1: Signal input of photoelectric sensor for loading of weighing scale.

E2: Check the output photoelectric sensor signal input of the weight balance.

Alarm light (has been connected when leaving the factory) :

L24V: Alarm light DC24V+, maximum output power 2VA.

L1: Buzzer.

L2: When the detection result is out of tolerance, the low output is valid until the next check begins.

L3: When the test result is qualified, the low output is valid until the next check begins.

L4: When the detection result is inferior, the low level output is effective until the next check starts.

Input (function can be customized, onsite connection according to actual demand) :

DI1: running input. In the stopped state, the input is valid and the system enters the running state.

DI2: Stop input. In the running state, the input is valid and the system enters the stop state.

DI3: EMD input. When this input is valid, it indicates that the device has entered metal detection.

DI4: Metal alarm status. When this input is valid, it indicates that the metal detection is not qualified.

DI5: EMD operation status. When this input is valid, it indicates that the metal detector is running.

DI6: STOP [Level]. In operating mode, pressing the emergency stop input is effective, and the system enters a stop state.

DI0V: switching quantity power supply DC24V-.

DI24V: Switching quantity power supply DC24V+.

4 transistor outlet (function can be customized, on-site according to the actual demand connection) :

DO1: No definition.

DO2: undefined.

DO3: undefined.

DO4: undefined.

DO0V: switching quantity supply power DC24V-.

DO24V: switch quantity power supply DC24V+.

DOCOM: switch quantity common end.

Sensor (already connected at factory) :

EX+ : Power positive, SN+ : induction positive, EX- : power negative, SN- : induction negative, SG+ : signal positive, SG- : signal negative.

Motor speed control communication interface (RS485) :

MT A: RS485 communication A.

MT B: RS485 Communications B.

MT G: RS485 Communication (GND).

8-way relay outlet (function can be customized, on-site connection according to actual demand) :

K1: defined as operation. When the system is in operation state, the relay output is closed, and K1A and K1B are switched on.Used to control the start and stop of frequency converter.

K2: defined as stop. When the system is in the stopped state, the relay output closes and K2A and K2B are switched on.This definition is the factory default setting and can be modified according to the actual needs.

K3: Unqualified Reject. The product inspection result is that the weight is not qualified, and within the duration of rejection, the relay output is closed, and K3A and K3B are conducting. Used to control the cylinder action of the unqualified rejection mechanism.

K4: Rejection of NG EMD. The product inspection result is that the metal detection is not qualified, and within the duration of removing the unqualified metal detection, the relay output is closed, and K4A and K4B are conducting. Used to control the cylinder action of the metal detection unqualified removal mechanism.

K5: Start EMD. When the system is in operation, the relay output is closed and K1A and K1B are conducting. Used to control the initiation of metal detector.

K6: Stop EMD. When the system is in a stopped state, the relay output is closed and K1A and K1B are conducting. Used to control the stop of metal detector.

K7: defined as qualified indication, after the product test is qualified, the relay output is closed,K7A,K7B on.This definition is the factory default setting, and can be modified according to the actual demand.

K8: defined as unqualified excluded. When unqualified occurs in the test result, the relay output is closed, and K8A and K8B are switched on.This definition is the factory default setting, and can be modified according to the actual demand.

2.5 Power supply power

AC220V±10%, 50/60Hz, 400W.

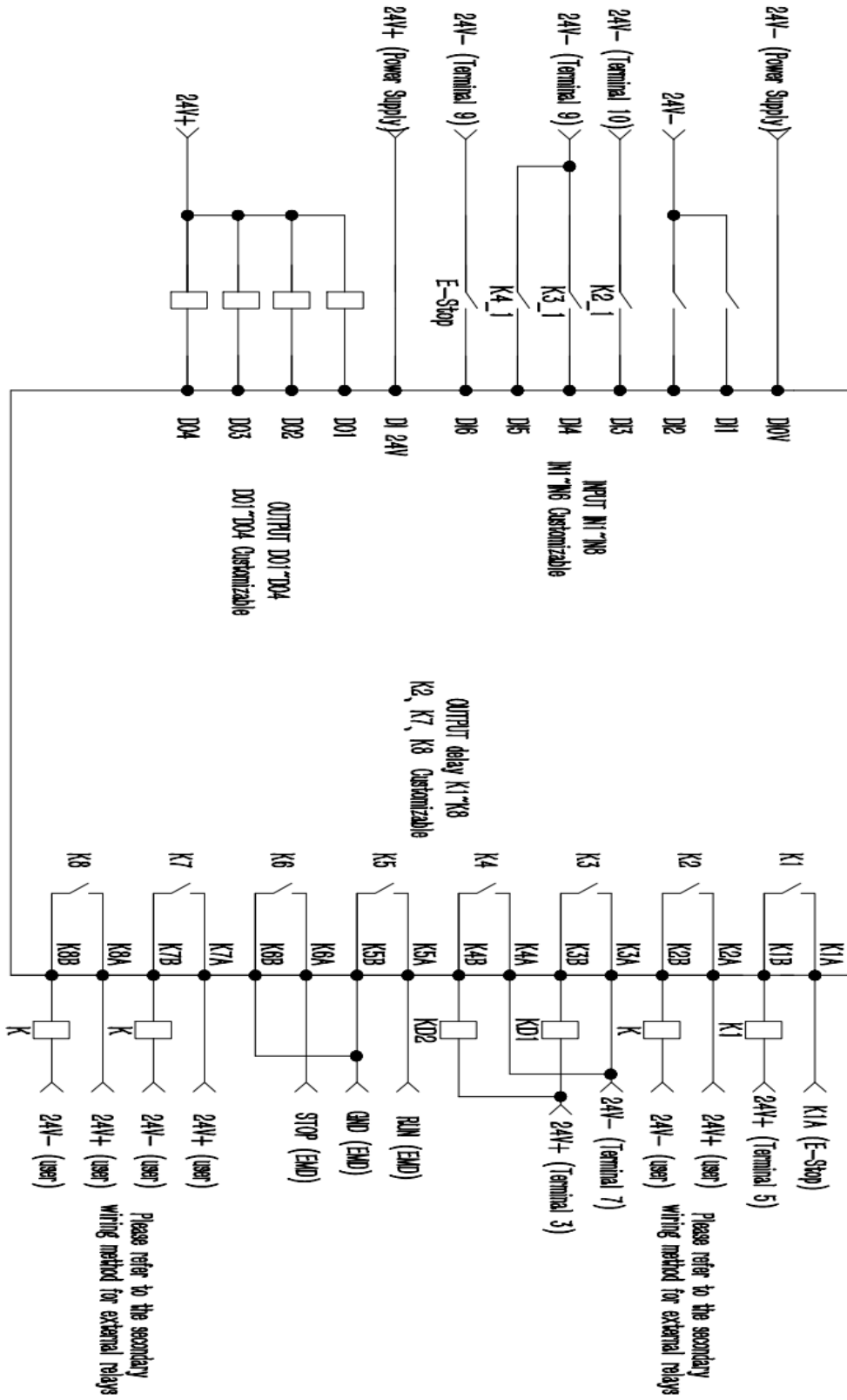

Figure 2-3 Schematic diagram of inlet and outlet connections

3. Operation

3.1 Operation summary

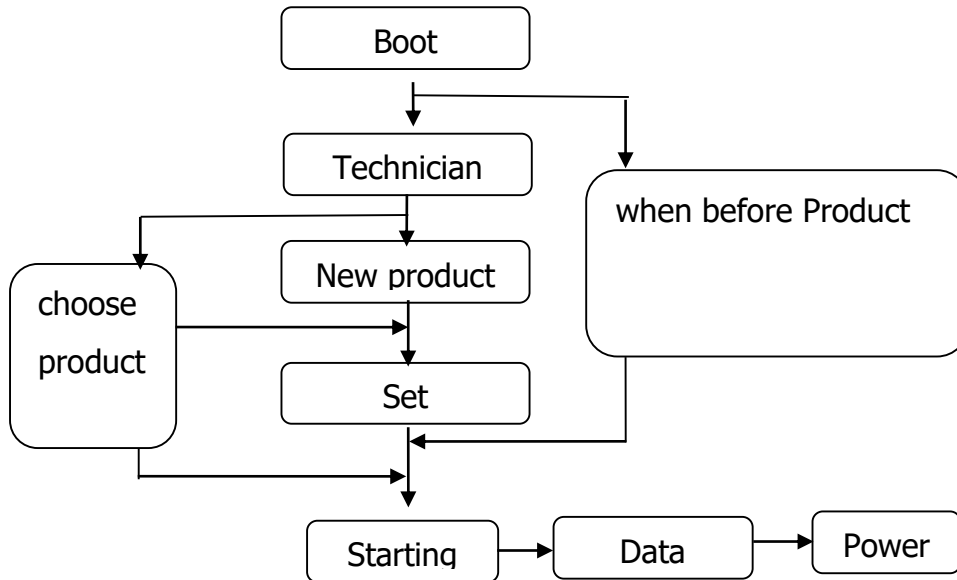

Figure 3-1 Procedure

3.2 Limit removal

Before use, it is necessary to first install the two limit shaft sleeves from the transportation position to the working position. The position indicated by the arrow in Figure 3-2 is the installation position of the limit shaft sleeve.

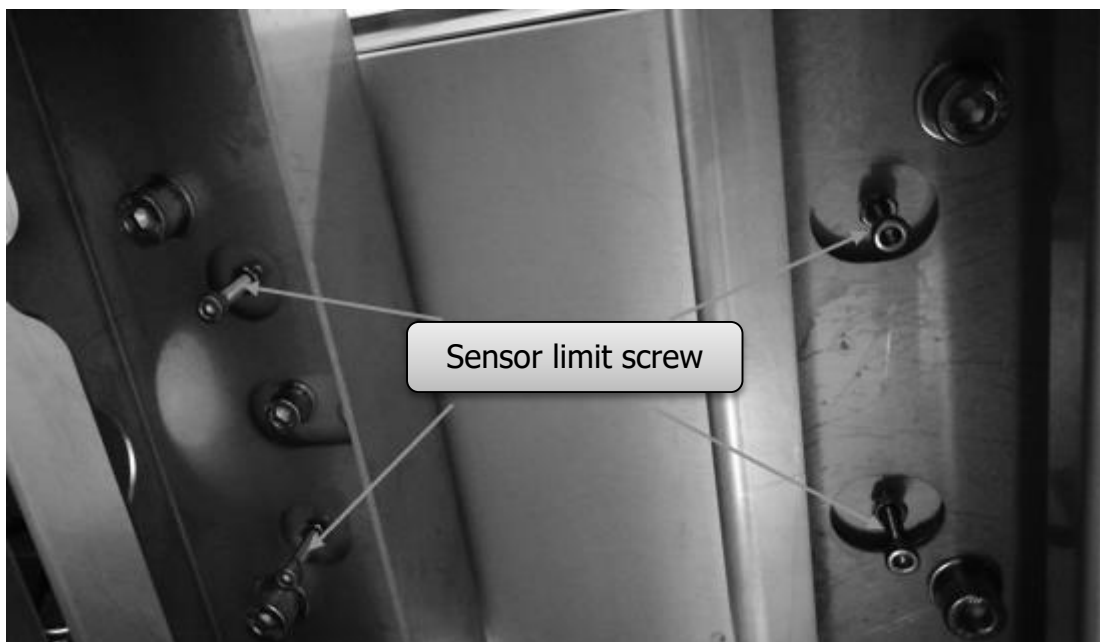

Figure 3-2 limit position

3.3 Basic operation

The main interface of weight inspection is used for daily production, which is used to start and stop the weight inspection belt, enter the relevant parameter interface and display the basic information of the tested product and the weight inspection result.

3.3.1 Power-on operation

Turn on the power and turn the knob switch to the "1" position and the boat type switch to the O position. The touch screen on the electric cabinet displays the initialization interface. At the top of the interface are USB insert mark, check scale model and time display; The black display area is the name of the current production inspection product, the weight display area, the weight unit display area and the weight check scale status display area; In the middle is the current setting of weight checking speed, the current actual weight checking speed and the display statistics of weight checking results; At the bottom are the function keys of the operation of the weight check scale and the parameters related to the weight check.

- Correct time parameters can effectively help users check the production inspection results, relevant production parameter changes and alarm information, help to improve the production pass rate and production speed and reduce production consumption.
- The weight display area of the weighing scale displays the real-time weight value in the stopped state, and displays the weight test result in the running state until the next object is effective.

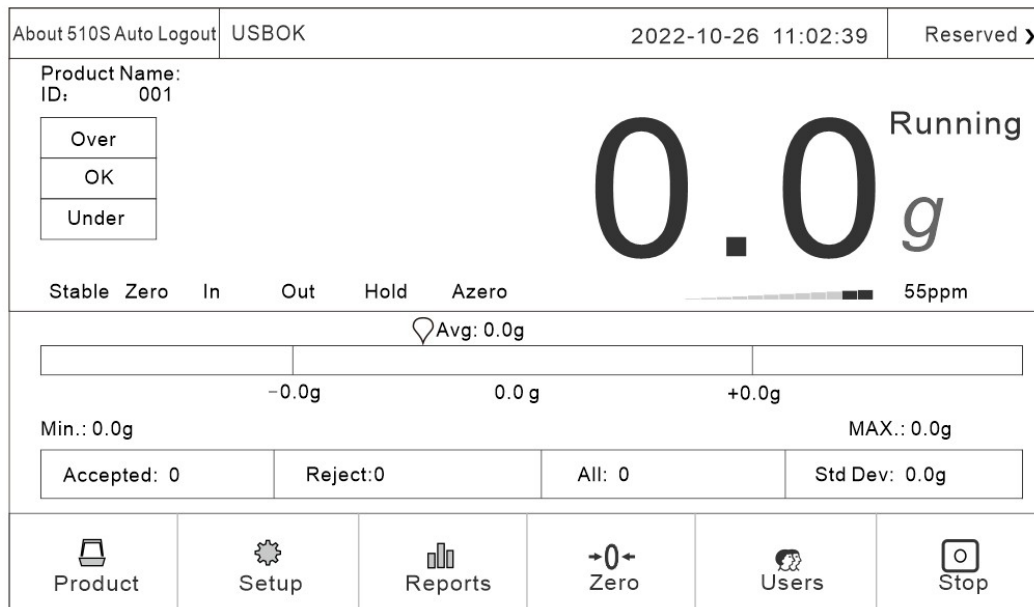













Figure 3-4 Power-on initialization interface

Button and operation frame operation instructions (applicable to all operation interfaces of the device) :

1.  **Product** Click this button to enter the interface of creating products and setting product parameters.
2.  **Setup** Click this button to enter the parameter setting interface.
3.  **Reports** Click this button to enter the data interface to view the relevant check data.
4.  **Zero** Click this button to clear zero.
5.  **Users** Click this button for user management operations.
6.  **Stop** Click this button to start and stop the device.
7.  **0 g** Click this type of action box to modify the value of this item.
8.  **192** Click the action box to modify the value of this item.
9.  **None** Click this type of action box to select Settings for this definition.
10.  **Change** Click this type of action box to perform the corresponding operation.
11.  Click this type of action box to open and close the corresponding function Settings.

3.3.2 Zero clear operation

If the touch screen displays the real-time weight value of the weighing scale in the stopped state is not zero (zero indicates the off state), click "Clear zero" to clear the weighing platform, so that the real-time weight value is displayed as zero, and then the zero indicates the on state.(It can be operated only in the stopped state).

If the weight check scale shows that the weight is unchanged, the stable identifier bit is on; otherwise, the stable identifier bit is off (the stable identifier bit is only related to the weight state, and has nothing to do with the operation of the weighing scale and the size of the weight value).

3.3.3 Start up operation

Click "Start" on the touch screen to start the weight checking scale, and the weight checking motor drives the weight checking belt to rotate. At this time, the operation label on the touch screen is "Running", and the weight checking operation can start.

3.3.4 Stop operation

Click "Stop" on the touch screen to stop the weight inspection belt and end the weight inspection process. At this time, the operation label on the touch screen is "Stopped".

3.3.5 Power off operation

Turn knob switch to "0" position, touch screen off, disconnect power. The above operations can only be performed when there is no weight product on the weighing scale.

3.4 User login

Under the touch screen initial interface, click "Product" or "Settings" to pop up the password login box, select the user to enter the corresponding password and click "Confirm" to log in. The initial passwords of the operator and administrator are written in the user description.

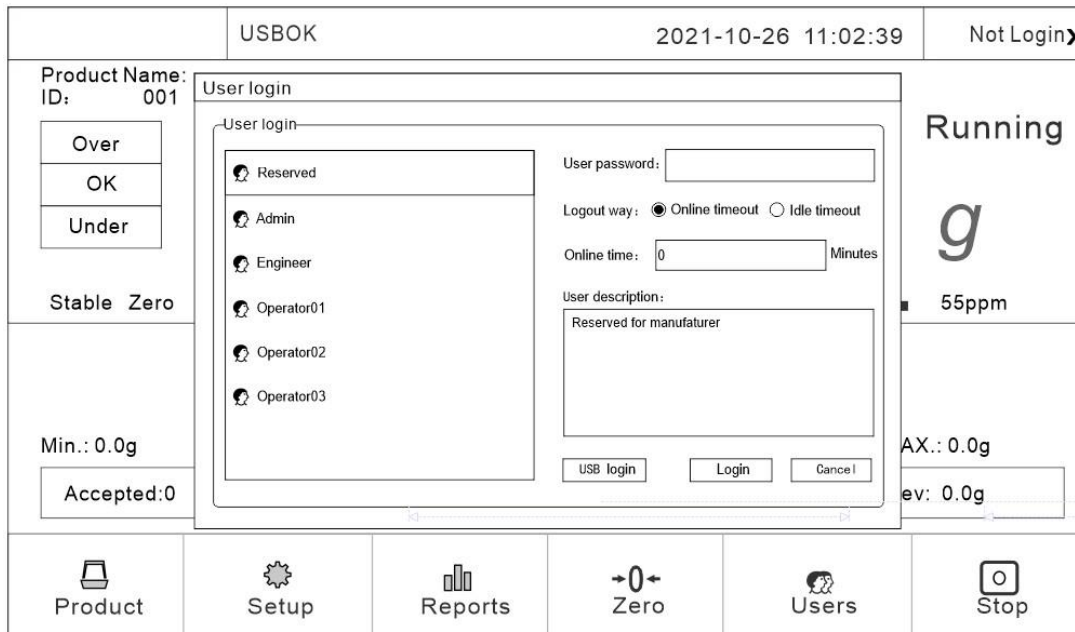

USBOK		2021-10-26 11:02:39	Not Login▶
Product Name: ID: 001	User login		Running
Over	Reserved	User password: <input type="text"/>	g
OK	Admin	Logout way: <input checked="" type="radio"/> Online timeout <input type="radio"/> Idle timeout	55ppm
Under	Engineer	Online time: <input type="text"/> Minutes	
Stable Zero	Operator01	User description: Reserved for manufacturer	
	Operator02	<input type="button" value="USB login"/> <input type="button" value="Login"/> <input type="button" value="Cancel"/>	AX.: 0.0g
Min.: 0.0g	Operator03		ev: 0.0g
Accepted:0			
<input type="button" value="Product"/>	<input type="button" value="Setup"/>	<input type="button" value="Reports"/>	<input type="button" value="Zero"/>
	<input type="button" value="Users"/>	<input type="button" value="Stop"/>	

Figure 3-5 Password input box

Product Setting		Product Name: 001		0.0 ^{Stopped} _g 0ppm		Reserved >	
? Help						2021-10-26 10:02:26	
Product ID		1		Passing Speed		0ppm >	
Product Name		<input type="text"/>		Belt Speed		0.00m/min	
Standard Weight		0.0g >		Weight Correction Factor		1456 >	
Hi Limit		0.0g >		Over Rejector Distance		0 mm >	
Lo Limit		0.0g >		Over Rejector Operating Time		0.000 S >	
Tare		0.0g >		Under Rejector Distance		0 mm >	
Unqualified Rejector Distance		0 mm >		Under Rejector Operating Time		0.000 S >	
Unqualified Rejector Operation Time		0.000 S >				Next Page >	
Product List		Product Parameter		Dynamic Calibration		EXIT	

Figure 3-7 Product parameters screen Example

Description of product parameters:

Name	Instructions
Product number	Number of the product under inspection
Speed of weight inspection	The speed at which the current weight checking device detects the product
Product name	Name of the product under inspection
Belt speed	Weigh the speed at which the belt is running
Standard weight	The standard weight of the product to be checked
Upper limit	In the process of weight inspection, if the weighing value is greater than the target value + the upper limit value, it will be judged as out of tolerance
Lower limit value	In the process of weight inspection, if the weighing value is less than the target value-lower limit value, it will be judged as undererror
Tare weight	The weight of the item's outer packaging

Qualified culling distance	The distance traveled by the product from the end of the scale to the start of the qualified culling mechanism
Duration of qualified culling	The duration of the qualifying cull mechanism's action
Out-of-tolerance culling distance	The distance traveled by the product from the end of the scale to the start of the offset removal mechanism
Underweight culling distance	The distance traveled by the product from the end of the scale to the start of the underbalance removal mechanism
The out-of-tolerance culling action time	The duration of the kill mechanism's action
Undershoot culling action time	The duration of the underkill operation
Unqualified culling distance	The distance traveled from the end of the scale to the nonconforming product after the start of the removal mechanism
The time of the unqualified culling action	The continuous action time of the rejection mechanism for nonconforming products (including out-of-error + undererror)
Correction factor	Standard no correction is 1000. Correction factor = $1000 + (\text{actual weight} - \text{test weight result}) / \text{min indexing}$. That is, if the weight test result is light, the correction factor is the number greater than 1000, if the weight test result is heavy, the correction factor is the number less than 1000
Total lot	Total number of pieces of heavy product inspected
Qualified batches	Number of eligible batches of products
Sampling starting percentage	The sampling data to this percentage is discarded after the object is placed on the scale
Percentage used for sampling	Data that is consistently used as a percentage from the start of sampling is used to calculate the weight check result

Dynamic zeroing filter grade	Filtering parameters in the weighing process
Dynamic clearing stability range	When the belt is running, within the stability determination time, the weight variation range is judged to be stable within this setting value, and only when it is stable can dynamic zeroing be allowed
Dynamic zeroing and stabilizing time	When the belt is running, within this setting value, the range of weight variation is judged as the stability of the scale platform within the range of dynamic zero clearance stability. Only when the stability allows the dynamic zero clearance
Maximum sampling time	Maximum sampling time during weighing
Average feeding times	When servo control is carried out, the average value of the set number of products is compared with the user's set value, and the difference between them is used as the basis of control. When it is 0, there is no need to fill the servo function
Servo pulse frequency	The pulse frequency value of the servo motor
Number of product delays	Equivalent to the number of objects from the charging machine to the photoelectric switch of the weighing scale. Also refers to the number of products passed before the next correction
Servo charging sensitivity	This setting is the adjusted weight corresponding to each correction pulse
Servo target value	Equivalent to the target value of package inspection weight
Exclusion of servo upper limit	When the weight is higher than this value, it does not participate in the average calculation and will generate an alarm
Exclude servo lower limit	When the weight is below this value, it does not participate in the average calculation and will generate an alarm
Servo dead zone	If the absolute weight error is less than this, no correction is made
Maximum servo modulation	Means the maximum allowable modulation correction

Exclude servo upper limit alarm stop	Exclude the servo upper limit alarm to stop
Exclude the servo lower limit alarm to stop	Exclude the servo lower limit alarm to stop
Failure to correct alarm stop in time	Failure to correct alarm stop in time
Metal detection switch	Turn on the switch to activate the metal detection function
Metal detection length	Physical length of metal detection belt running direction
Distance from metal detection photoelectricity to scale platform center	Distance from metal detection feeding photoelectric to the center of weighing platform
Metal detection distance threshold	The distance collected up and down centered on the detection point
Metal detection removal distance	The distance traveled by the end of the weighing platform to the unqualified products in the metal detection after the removal mechanism starts to operate
Metal detection and removal action time	Duration of metal detection and removal mechanism action

3.5.3 Modify product parameters

On the Product list page, select the product whose parameters you want to modify from the product list and click "Product Parameters" to enter the product parameters interface to modify the selected product parameters (the newly added product directly jumps to the product parameters interface).

- The standard weight refers to the weight of the product to be checked, and the upper and lower limit is the allowable deviation value of qualified product; If it is not necessary to calculate the packaging weight of the product, the outer packaging weight of the product can be written into the tare weight column, and the net weight should be filled

in the standard weight column.

- The product number is automatically generated by the system; The linear speed of the belt is calculated from the detection speed, and changes with the change of the detection speed. It cannot be filled in (the linear speed of the belt should be consistent with the linear speed of the front and rear end conveying mechanism).
- The compensation weight difference value is calculated by dynamic calibration. Under normal circumstances, manual change is prohibited to prevent deviation between the product weight and the actual weight.
- When filling in the product parameters, attention should be paid to its value range. Generally, if it is lower than the lower limit of the parameter range, the parameter value will remain unchanged; if it is higher than the upper limit of the parameter range, the upper limit of the parameter range will be written by default.
- The definition of weight checking speed, belt speed and correction coefficient is described in detail on the help interface of product parameters. If necessary, you can click "Help" to view.

3.5.4 Delete product parameters

On the product list page, select the product to be deleted and click "Delete Product" to delete the product. After deleting the product, the following product parameters will move forward in order, and the product number will move forward. The product cannot be deleted during the operation of the weight check scale; In order to prevent product parameters from being incorrectly deleted, the product name should be set reasonably when setting product parameters.

3.6 Calibration scale

In order to ensure the correct weight of the weighing scale and the linearity of the weight change, each weighing scale needs to carry out weight calibration and dynamic calibration. For specific operation methods, please refer to "Operation Instructions on Buttons and Operation Frames" in section 3.3.2.

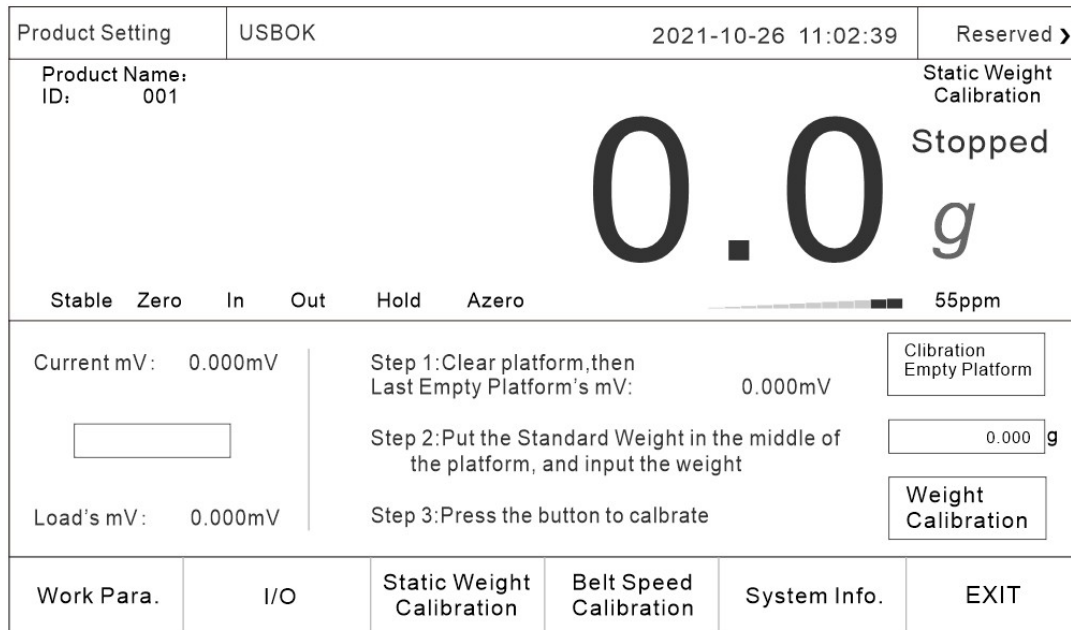

Figure 3–11 shows an example of the weight calibration interface

Description of static calibration parameters:

Name	Instructions
Calibrate the empty scale table	Eliminate external interference, the scale table at zero and stable, can be clicked
Calibrate the scale weight	Enter the weight of the calibration weight
The weight calibration scale	Put the weight on and after entering the weight of the weight, click
Current voltage value	The current voltage value of the sensor
Empty scale voltage value	The voltage value of the sensor when the top of the scale is emptied
Weight voltage value	The voltage value of the sensor after placing the weight

3.6.1 The weight calibration scale

In the setting page, click "Static calibration" to enter the interface of weight calibration, follow the steps on the touch screen to calibrate the scale, and click "Exit" to return to the main interface after the calibration is completed. For specific operation methods, please refer to "Operation Instructions on Buttons and Operation Frames" in Section 3.3.2.

- During calibration, ensure that the weighing scale is in the stopped state; otherwise, the interface of the weighing scale cannot be entered; Calibration should ensure that there is no item on the weighing platform, no vibration on the weighing platform, and no relatively strong air flow around the weighing scale.
- When the weighing platform is empty, ensure that the weighing platform is at zero position and stable. Otherwise, please eliminate interference and click "Calibrate the weighing platform". The second step can only be carried out when the touch screen indicator is 0 and the stability sign is lit.
- When placing the weight, try to avoid the weight hitting the surface of the weighing platform. Enter the correct weight into the weight box of the weighing platform, otherwise it will lead to inaccurate calibration scale or calibration failure (the weight of the weighing platform should be greater than the product weight and not exceed the maximum range of the weighing scale).
- If the calibration fails, please check whether the scale is stable and whether the sensor is interfered by the outside world or whether the scale is in contact with other equipment, and re-calibrate after troubleshooting.

3.6.2 Dynamic calibration of scale

On the product page, click "Dynamic calibration" to enter the dynamic calibration interface, and perform dynamic calibration according to the text prompts. When completed, relevant parameters will be automatically calculated and generated and product parameters will be written. Click "Exit" to return to the main interface after completion of calibration. For details, please refer to Section 3.3.2 "Operation Instructions for Buttons and Operation Frames".

Product Setting	? Help	2021-10-26 11:02:39	Reserved >
Product Name: ID: 001		Dynamic Calibration	
<div style="font-size: 48px; font-weight: bold;">0.0</div> <div style="font-size: 24px; font-weight: bold;">g</div>		Stopped	
Stable	Zero	In	Out
Hold	Azero	55ppm	
Step 1: Clear platform, then		Zero	Max. Weight: 0g
Step 2: Put the standard product in the middle of the platform and press		Getting Static Weight	Avg. Weight: 0g
Step 3: Use the same tested product,		Start	Min. Weight: 0g
Run <input type="text" value="00"/> Times!			Correction Factor: 0
Work Para.	I/O	Static Weight Calibration	Belt Speed Calibration
		System Info.	EXIT

Figure 3-12 Dynamic calibration screen example

Description of dynamic calibration parameters:

Name	Instructions
Zeroing	Clear the current weight value to zero
Get the weight	Stop the belt running and put the test material on after the static weight value shown
Dynamic calibration times	The number of repeated runs of dynamic calibration. The default is ten, and no less than five are recommended
Start up	The belt will run, and after the statically weighed object has passed, it should be moved back to the front stage, repeatedly running dynamically, and the controller will automatically record the dynamic weight. General dynamic calibration ten times, the number of dynamic calibration to check the weight scale will automatically stop
Maximum weight	The maximum value of the weight check result during dynamic calibration
Average weight	During dynamic calibration, the average weight of each check will be updated after the number of dynamic calibration is completed
Correction factor	<p>The standard value is 1000. After the number of dynamic calibration is completed, the controller will automatically calculate this value according to the dynamic result and static weight.</p> <p>If it is not convenient for dynamic calibration, you need to enter this value manually, which can be set in the product parameter interface, and fill in the size of the value refer to the method in the dynamic calibration parameter help interface</p>

- Calibration must ensure that the check scale in the stopped state, otherwise can not enter the dynamic calibration interface; When calibrating, ensure that there is no item on the scale, no vibration on the scale, and no relatively strong air flow around the scale.
- When the weighing platform is empty, it should be ensured that the weighing platform is at zero position and stable, otherwise, please eliminate external interference and carry out "zero clearing" operation.
- When placing the product, the product should avoid hitting the surface of the weighing platform. Only after the weight is stable can you click "Obtain static weight"; If the product has a gross weight value, please set the gross weight value first before

dynamic calibration.

- The default value of learning times is 10. If the learning result is not accurate, you can increase the learning times appropriately. If the production requirement is not high, the learning times can be appropriately reduced to improve the learning speed; External interference should be avoided in the learning process, and the system will automatically save the learning results and display them after the completion of learning.
- The change of product detection speed requires dynamic calibration again.
- The principle of dynamic calibration, attention to implementation and alternative methods are introduced in detail in the interface of dynamic calibration parameter help. If necessary, you can click Help to view.

4.2 Statistics

Click "Statistics Data" to enter the check weight data statistics interface, which displays product distribution intuitively. Click "Print data" to print statistics information, click "Export data" to export statistics information to the USB disk inserted into the touch screen, click "Delete data" to clear statistics information. For specific operation methods, refer to "Operation Instructions on Buttons and Operation Frames" in Section 3.3.2.

- Statistics include out of tolerance, under tolerance, the cumulative number of inspection times of qualified products, weight, average value and probability distribution, etc.
- Before testing a new batch of product, the previous statistics should be cleared, otherwise the new product will accumulate on the original statistics and generate incorrect statistics.

Data Reports		2021-10-26 11:02:39		Reserved ▶	
Product Name:		Standard Weight:0.000 kg			
ID: 001		Tare: 0.000 kg			
Items	Total of Number	Total of Weight	Avg.Weight		
Total:	0	0.000 kg	0.000 kg	Print Data	
Total of Qualified:	0	0.000 kg	0.000 kg		
Total of Over:	0	0.000 kg	0.000 kg	Export Data to U-disk	
Total of Under:	0	0.000 kg	0.000 kg		
Total of Unqualified:	0	0.000 kg	0.000 kg		
Total of Untreated:	0	-	-	Delete Data	
Qualify Rate: 0.00%		Max. Weight: 0.000 kg		Min. Weight: 0.000kg	
Check Datd Historical	Trend Chart	Statistical Chart	Data Statistical	NULL	Alarm Historical EXIT

Figure 4-2 An example of the statistics page

4.3 Alarm information

Click "alarm record" to enter the interface for viewing alarm records, and you can view the alarm information in the process of weight inspection, including alarm serial number, alarm time, number and alarm content. For specific operation methods, please refer to "Operation Instructions of Button and Operation Frame" in Section 3.3.2.

Data Reports		2021-10-26 11:02:39		Reserved >	
Index	Time	Alarm	Alarm Information	<input type="text" value="0"/> <input type="button" value="Export Data to U-disk"/> <input type="button" value="Delete Data"/>	
<<		0/000000		>>	
Check Datd Historical	Trend Chart	Statistical Chart	Data Statistical	NULL	Alarm Historical EXIT

Figure 4-3 Alarm information screen example

4.4 Statistical graph

Click "Statistical Chart" to enter the statistical chart interface to visually view the product weight distribution.

Data Reports		2021-10-26 11:02:39		Reserved >	
Total:	<input type="text" value="0"/>				
Total of Qualified:	<input type="text" value="0.00%:00"/>				
Total of Over:	<input type="text" value="0.00%:00"/>				
Total of Under:	<input type="text" value="0.00%:00"/>				
Total of Unqualified:	<input type="text" value="0.00%:00"/>				
Total of Untreated:	<input type="text" value="-. --%:--"/>				
Check Datd Historical	Trend Chart	Statistical Chart	Data Statistical	NULL	Alarm Historical EXIT

Figure 4-4 Example of the statistical chart interface

5. Quantity of switches

5.1 I/O I/O testing

System Setting		Product Name: ID: 001		<div style="font-size: 2em; font-weight: bold;">0.0</div> <div style="font-size: 0.8em;">g 0ppm</div>		Stopped		Reserved >		2021-10-26 10:02:26	
Relay-K1	Run	K1 OFF	Change	IN-DI1	Run	DI1 OFF					
Relay-K2	Stop	K2 OFF	Change	IN-DI2	Stop	DI2 OFF					
Relay-K3	Unqualified Reject	K3 OFF	Change	IN-DI3	EMD input	DI3 OFF					
Relay-K4	Reject of NG EMD	K4 OFF	Change	IN-DI4	Metal alarm status	DI4 OFF					
Relay-K5	Start EMD	K5 OFF	Change	IN-DI5	EMD operation status	DI5 OFF					
Relay-K6	Stop EMD	K6 OFF	Change	IN-DI6	STOP[Level]	DI6 OFF					
Relay-K7	OK	K7 OFF	Change	I/O Test		<input type="checkbox"/>		Next Page >			
Relay-K8	Busy&Stop	K8 OFF	Change								
Work Para.	I/O	Static Weight Calibration	Belt Speed Calibration	System Info.	EXIT						

Figure 5-1 I/O parameter screen Example 1

System Setting		Product Name: ID: 001		<div style="font-size: 2em; font-weight: bold;">0.0</div> <div style="font-size: 0.8em;">g 0ppm</div>		Stopped		Reserved >		2021-10-26 10:02:26	
OUT-DO1	None	DO1 OFF	Change	E-1	Input Photoelectric Sensor	E1 OFF					
OUT-DO1	None	DO2 OFF	Change	E-2	Output Photoelectric Sensor	E2 OFF					
OUT-DO1	None	DO3 OFF	Change								
OUT-DO1	None	DO4 OFF	Change								
3-Colors Buzer Lamp	Red OFF	Green OFF	Yellow OFF	Buzer OFF	Change						
< Previous Page			I/O Test		<input type="checkbox"/>						
Work Para.	I/O	Static Weight Calibration	Belt Speed Calibration	System Info.	EXIT						

Figure 5-2 I/O parameter screen example 2

Click "Switch quantity" on the setting page to enter the IO test interface. The system provides 6 input terminals and 12 output terminals, which users can decide whether to use

according to production requirements. For specific operation methods, please refer to "Operation Instructions on Buttons and Operation Frames" in Section 3.3.2.

IO test is to test whether the IO port is properly connected to the external device. During the test, click "Switch" after the output to output 1-8. If the corresponding relay coil is closed (red indicator light on the relay base) and the corresponding device is in action, the connection is normal and the output point of the weighing scale is valid; otherwise, please check whether the connection between the output point and the device is correct; Click the "switch" behind the three-color light, if the three-color indicator light is on, the connection is correct.

The input test can be carried out by setting the low level signal (DC0V) at the input end. If the low level signal is effective at the corresponding input port, the test indicator box behind the corresponding input point ON the touch screen will light up and display "ON" (The photoelectric input can be blocked on the main interface when testing the photoelectric input, if the corresponding input and discharge marks are lit up, the photoelectric input is effective). The input and output signals can be defined by themselves.

The default switching quantity is defined as follows:

Enter the port number	Definition	Output port number	Definition
DI1	Run	Relay -K1	Run
DI2	Stop	Relay -K2	Stop
DI3	EMD input	Relay -K3	Unqualified
DI4	Metal alarm status	Relay -K4	Reject of NG EMD
DI5	EMD operation status	Relay -K5	Start EMD
DI6	STOP[Level]	Relay -K6	Stopt EMD
E1	I1 (incoming photoelectric sensor)	Relay -K7	Qualified indication
E2	I2 (discharge photoelectric sensor)	Relay -K8	Disqualified cull
		DO 1	Undefined
		DO 2	Undefined
		DO 3	Undefined

		DO 4	Undefined
		L 1	O17 (Buzzer alarm output)
		L 2	O7 (alarm light out-of-tolerance indication, no relay)
		L 3	O10 (alarm light qualified indication, no relay)
		L 4	O6 (alarm light undererror indication, no relay)

List of definable switching quantities:

Enter switch quantity:

Number	Name	Function description
I00	Undefined	No function when this item is selected.
I01	Input photoelectric	When the input is valid, it means that the input photoelectric sensor has sensed the measured object
I02	Output photoelectric	When the input is valid, it means that the output photoelectric sensor has sensed the object under test
I03	Run	When the input is valid, the device will boot into the running state
I04	Stop	The device will stop running when the input is valid
I05	Clear alarm	When the input is valid, the device will clear the current alarm
I06	Aberration cull complete	When the input is valid, the offset cull is complete
I07	Owe culling complete	When the input is valid, the underbalance culling has been completed
I08	Packet detection	When the input is valid, the device performs packet connection detection
I09	Belt speed detection	
I10	Run/stop [level]	Control device operation or stop by level signal

I11	Run/stop [edge]	When the device is in the stopped state, the signal input is effective, the device starts to enter the running state; When the signal input is effective, the device stops running;
I12	Stop [level]	The signal is valid and the touch screen cannot start the device
I13	EMD input	The signal is valid, and the equipment performs metal detection
I14	Metal alarm status	The signal is valid, indicating that the metal detection is not qualified
I15	EMD operation status	The signal is valid, indicating that the metal detection is in operation

Output switching quantity:

Number	Name	Function description
O00	Undefined	No function when this item is selected.
O01	Out-of-tolerance indication	If the weight check result is out of tolerance, the output is valid and continues until the next weight check is completed.
O02	Owe indication	If the weight check result is underweight, the output is valid and lasts until the next weight check is completed.
O03	Run	Run status output is valid.
O04	Stop	The stopped state output is valid.
O05	Alarm	Output is valid when alarming.
O06	Out-of-order culling	The weight check result is out of tolerance, according to the set out of tolerance eliminator distance delay, and then according to the set duration output valid.
O07	Owe culling	The weight check result is the undererror, according to the set offset culler distance delay, and then according to the set duration output valid.
O08	Disqualified culling	The weight inspection result is out of tolerance or undertolerance, according to the set distance delay of the unqualified eliminator, and then according to the set duration output effective.

O09	Number of batches completed	This output is valid when the set number of batches is reached.
O10	Qualifying instructions	If the weight check result is underweight, the output is valid and continues until the next weight check is completed.
O11	Busy Stop + communication	When the system is in busy state, busy detection is valid, this output is invalid, busy state is invalid and communication command is received, this output is valid, busy detection is invalid, this output is valid
O12	Busy stop	When the system is in busy state, busy detection is valid and this output is invalid, busy state is invalid, this output is valid, busy detection is invalid, this output is valid
O13	Feed photoelectric output	According to the state of the input photoelectric output, the input photoelectric effective, then the output effective.
O14	Discharge photoelectric output	According to the state output of discharge photoelectric, discharge photoelectric is effective, then the output is effective.
O15	Speed up pulse	Servo feedback function
O16	Deceleration pulse	Servo feedback function
O17	Buzzer alarm output	Output in different ways depending on your choice
O18	Qualified Cull	
O19	Start EMD	When the metal detection switch is turned on, the operating status output is valid
O20	Stop EMD	When the metal detection switch is turned on, the stop state output is valid
O21	Reject of NG EMD	The metal inspection result is unqualified. According to the set distance delay of the metal detection unqualified remover, and then output valid according to the set duration

6. Working parameters

6.1 Working parameter Settings

Click "Set" to enter the interface of working parameters, and the user can decide whether to open according to the production needs. If the corresponding alarm is generated after opening, the weight checking scale will automatically alarm or alarm stop. It needs to manually click "clear alarm" or input the signal of "clear alarm" to start the weight checking again (after the alarm is generated and until the clear alarm is completed, The motor of the check weighing scale runs but does not determine whether the object is on or off the weighing platform, nor does it carry out weighing operation), and the alarm information is stored in "Data" - "Alarm information". For specific operation methods, please refer to "Operation Instructions of Button and Operation Frame" in section 3.3.2.

System Setting		Product Name: ID: 001		0.0 <small>g</small> Stopped <small>0ppm</small>		Reserved >		2021-10-26 10:02:26	
Over/Under Queue Full Alarm&Stop			<input type="checkbox"/>	Over/Under Alarm&Stop			<input type="checkbox"/>	>	
Rejector Miss Alarm&Stop			<input type="checkbox"/>	Display Over/Under in MainPage			<input type="checkbox"/>	>	
System Busy Alarm&Stop			<input type="checkbox"/>	Main Display Results only when Running			<input type="checkbox"/>	>	
Blocking Time Over Error Alarm&stop			<input type="checkbox"/>	Sub Display Real Weight			<input type="checkbox"/>	>	
Weighing Timeout Alarm&Stop			<input type="checkbox"/>	Continuous Packs Not Reject			<input type="checkbox"/>	>	
Cont. Unqualified Alarm&Stop			<input type="checkbox"/>	Photoelectric Sensor Blowing Interval Time			0 S	>	
Auto ZERO Failure Alarm&Stop			<input type="checkbox"/>	Photoelectric Sensor Blowing Opprating Time			0 S	>	
Motor Overload Alarm&Stop			<input type="checkbox"/>	>					
Work Para.		I/O	Static Weight Calibration	Belt Speed Calibration	System Info.	EXIT			

Figure 6-1 Working parameters screen example

Analysis of working parameters:

Name	Instructions
The alarm stops when the queue is full	The default number of over/under error queue is 20, which means that if the removal distance is long enough, that is, it takes a long time for the products to be removed to arrive at the removal institution, there can be more than 20 products in the middle. If there are more than or equal to 20 over/under error products to be removed in this distance, it will alarm and stop

If not eliminated in time, the alarm will be stopped	After the next unqualified product has gone through the reinspection process, the last product has not been removed, the alarm will be stopped
Busy alarm stop	In the last product has not been out of the inspection belt, the next product into the inspection belt, it will show busy alarm and stop. If the back end is connected with an over and under error elimination mechanism, the default is over error elimination
The time of overplugging will alarm and stop the machine	Indicates that if the discharge photoelectric induction continues, and exceeds the plugging time set in the system parameter interface, it will alarm and stop
If the maximum time on the scale is exceeded, it will alarm and stop	There are two kinds of action; 1. If the maximum time on the scale set on the touch screen is more than 2 times of the time required for the object to pass the scale, the maximum alarm time on the scale is twice of the time required for the object to pass the scale. 2. If the maximum time on the weighing platform set on the touch screen is less than or equal to twice the time required for the object to pass the weighing platform, the maximum alarm time on the weighing platform is the maximum time on the weighing platform set on the touch screen
The number of consecutive unqualified alarms	The number of consecutive failed alarms
The number of super continuous disconformance alarm stops	In the product parameter setting interface, you can set the alarm number of continuous nonconformance. If the set value is not zero and the switch is on, the number of continuous nonconformance will alarm and stop when it reaches this value
Upper limit of motor load	The maximum load the motor can withstand

Stop above the motor load limit	The upper limit of motor load can be set in the system parameter interface of the product. When the weight of the product or the object to be weighed exceeds the set upper limit, it will alarm and stop
Overweight or underweight alarm and stop	Display on the main page that the result of this test product is out of tolerance or under tolerance and the device will stop. If you need to use this function, you need to move forward the discharge photoelectric position, please contact our technical department for details
The main page displays the information of overshoot and undershoot	On the main page, it shows that the result of this test is out of tolerance, under tolerance, or qualified
The main page will display only the weight test result	Only the product weight test result of this test is displayed on the main page
Auxiliary display of real-time weight	Display the detected real-time product weight on the main page
Units	g/kg/t Optional
Minimum indexing	0.001. 0.002. 0.005. 0.010. 0.020. 0.050 Optional
Check scale for stability range	When calibrating the scale, the weight variation range is judged to be stable within this setting value
Judge the range of stability;	During the stabilization time, the range of weight variation is judged to be stable within this setting value
Zero tracking range	Weight value within this range, automatically clear zero
Clear range	The range at which the scale table is zeroed out during weighing

Automatic zeroing at startup	Perform zero clearing once the scale platform is started
Check the maximum judgment time of the scale	Is the longest judgment time in the process of weight calibration, indicating that the weighing platform must be stable and the zero voltage must be within the limited range during the calibration of the empty weighing platform and the weight calibration process. If the above conditions are not met and the maximum judgment time is exceeded, the alarm will be given and the weighing will fail
Decimal point	0 0.0 0.00 0.000 0.0000 Optional
Maximum range	1.2kg
Check scale for stability time	When checking the scale, the range of weight variation is judged to be stable within the stability range of the scale
Stabilizing time	Within this setting, the range of weight variation is judged to be stable within the range of stability
Zero tracking time	During this time, the system data drift does not exceed the zero tracking range
The system automatically clears zeros after power-on	Zero clearing operation will be performed once on the scale platform
Feed to shake time	Do not sample during this time after feeding
Time to remove shaking from material	Do not sample during this time before discharging
Length of scale table	400mm
Maximum time on the scale table	Maximum time an item is on the scale
Material blocking time	From the discharge photoelectric induction to the material time, more than this time alarm

Dynamic zero clearance range	Range of zeroing of the weighing platform during the weight checking process
Digital filtering level	0 to 9 can be set
AD sampling rate	120 beats per second 240 beats per second 480 beats per second
Pre-filter grade	0 to 20 optional
Time between photoelectric dust removal	When the system runs to the set value, the photoelectric dust removal begins
Duration of photoelectric dust removal	The output time of the photoelectric dust removal switch
Buzzer buzzer type	There are four types to choose from, which are undererror, out-of-error, unqualified, and qualified
Buzzer sounding mode	There are three ways to choose from, long buzzer, off, and delay
Buzzer delay time	The delay time is 0.000-10.000S
When the overgap is not suspended, the pop-up window will alarm	When the overgap is not suspended, the pop-up window displays the alarm information
The over and under alarm is included in the alarm record	The over and under alarm is included in the alarm record

7. Communication

The product has RS485 and optional network port for external communication. The communication protocol is standard Modbus RTU, and the network port communication includes Modbus TCP/IP and HTTP. When the communication mode is printed, RS485 can be connected to the printer for printing output. For detailed operation methods, refer to "Operation Instructions on Buttons and Operation Frames" in section 3.3.2.

7.1 Communication parameters

Click "Setting" to enter the interface of working parameters, and then click the next page, the user can set the relevant serial port communication mode, to realize the communication between the weighing scale and the host computer and other external control units or connect the printer.

System Setting		Product Name: ID: 001		0.0 Stopped g 0ppm		Reserved >		2021-10-26 10:02:26	
< Previous Page									
COM1 Mode			Modbus-RTU >		COM2 Mode			Modbus-RTU >	
Slave ID			001 >		Slave ID			001 >	
BAUD			57600 >		BAUD			57600 >	
Byte Format			8-E-1 >		Byte Format			8-E-1 >	
Dword Data Format			AB-CD >		Dword Data Format			AB-CD >	
					Next Page >				
Work Para.	I/O	Static Weight Calibration	Belt Speed Calibration	System Info.	EXIT				

Figure 7-1 Communication parameters interface Example 1

System Setting		Product Name: ID: 001		0.0 <small>Stopped</small> <i>g</i> <small>0ppm</small>		Reserved >		2021-10-26 10:02:26	
< Previous Page									
COM3 Mode			Modbus-RTU >		LAN Mode			Modbus-TCP/IP >	
Slave ID			001 >		IP			192 · 168 · 071 · 101	
BAUD			57600 >		Port			502 >	
Byte Format			8-E-1 >		LAN MAC			BC AA BB CC 01 02	
Dword Data Format			AB-CD >						
					Next Page >				
Work Para.	I/O	Static Weight Calibration	Belt Speed Calibration	System Info.	EXIT				

Figure 7-2 Communication parameters screen Example 2

Description of communication parameters:

Name	Instructions
Serial communication method	Modbus-RTU
Mailing address	The address of the current device
Baud rate	Baud rate for current device communication
Byte format	The byte format of the current device communication. Default 8-E-1
High and low bytes	Bytes of current device communication. Default AB-CD
Network port communication mode	Network port communication mode
IP address	IP address for current device communication
Port number	Port number for current device communication
MAC address	MAC address for current device communication

7.1.1 Serial port communication

The weighing scale is configured with three serial ports, which can communicate with the host computer through RS485 serial ports. The optional functions are Modbus-RTU and print mode (serial port three can only be set as print). The data format 7-E-1 is fixed as print, and Modbus-RTU communication cannot be carried out.

Serial number	Range	Instructions
Mailing address	1 to 245	Check the weight scale slave number
Communication method	Modbus-RTU, print	Communication Modes and functions
Baud rate	9,600, 19,200, 38,400, 57600 and 115,200	Communication data transfer speed
Data format	7-E-1(Print), 8-e-1, 8-n-1.	Communication transmission data Format
High and low bytes	High word first or low word first	Facilitate communication of various upper computers

When the host computer communicates with multiple weighing scales at the same time, the code of each weighing scale device cannot be consistent, and the maximum value is 245 (that is, a single PC can be connected to 245 weighing scales at the same time).

7.1.2 Network port communication

The weighing scale can communicate with the host computer through a 10M/100M adaptive network port. The optional functions are Modbus TCP/IP and HTTP protocol. Parameter setting requirements are as follows:

Serial number	Instructions
IP	The upper computer and the motherboard must be in the same network segment and not equal
Port number	Range 0-65535, usually set to 502 for slave
MAC address	The address of each device cannot be repeated and is set before delivery

HTTP works in server-side mode, and the protocol is as follows:

- 1 Send: http://IP,
Return: current weigh value (screen display value).
For example:
Send to: http://192.168.61.223
Return: 123.456kg
- 2 Send:
http://IP/szgmt.html
Return: Current weighing value (screen display value).
For example:
Send: http://192.168.10.15/szgmt.html
Return: 123.456kg
- 3 Send:
http://IP/cwrf.html
Return: Current weigh value (screen display value), new weigh data identification.
For example:
Send: http://192.168.10.15/cwrf.html
Return: 123.456kg0 (This value changes from 0 to 1 or from 1 to 0 when there is a new check result)
- 4 Send:
http://IP/crf.html
Return: New weigh data identification.
Example:
Send to: http://192.168.10.15/crf.html
Return: 1 (change the value from 0 to 1 or from 1 to 0 when there is a new check result)

7.1.3 MAC address

The MAC address is the physical address of the weighing scale and cannot be modified. It represents the identification number of the weighing scale.

7.2 The Modbus register communication address is defined

PLC address	Module address	Parameter definition	Remarks	
Home screen status (Support function code 0x03)				
40001	0000	Module current status 1	.0	1: Weight positive overflow
			.1	1: The sensor is overflowing

			.2	1: Weight negative overflow
			.3	1: Negative sensor overflow
			.4	1: Weight plus or minus identifier bit 0: plus 1: minus
			.5	1: zero point identifier bit
			.6	1: Stabilize the identifier bit
			...	reserve
			.12	1: Static calibration state
			.13	1: Zero point calibration is successful
			.14	1: Gain calibration is successful
			.15	Reservations
40002	0001	Module current status 2	.0	1: Run 0: Stop
			.1	1: Upper limit (for indication)
			.2	1: Lower limit (for indication)
			.3	1: Qualified (for indication)
			.4	1: out of tolerance (for culling)
			.5	1: Underbalance (for culling)
			.6.	1: Qualified
			.7.	1: Busy (for indication)
			.8.	1: IO test

			.9.	1: Belt calibration
			.10	1: Dynamic calibration
			.11	1: Feed
			.12	1: Discharge
			.13	1: Keep
			.14	1: Return to zero
			...	reserve
40007	0006	Weight value	Stop status: real-time weight;Running state: weight check result	
40008	0007			
40539	0538	Out-of-tolerance ratio		
40540	0539			
40541	0540	Underdifference ratio		
40542	0541			
40551	0550	Error number	1: Busy	
			2: Not removed in time	
			3: Continuous disqualification	
			4: Total batch completed	
5: Qualified batch completed				
6: Block the material				
There is no				
8: Super maximum sampling time				
9: Super motor load				
40563	0562	Actual weight check speed	The number of products that actually pass the weighing scale in one	
40564	0563			

			minute during the product weighing process
Product parameters (Function codes 0x03, 0x10 supported.)			
40101	0100	Product number	Read: Currently selected product number; Write: Write needs to select the product number and update to write value after writing
40102	0101		
40103	0102	Product weight	Static weight of the product to be checked
40104	0103		
40105	0104	Upper limit	Allowable upper deviation of product conformity
40106	0105		
40107	0106	Lower limit	The permissible lower deviation of product conformity
40108	0107		
40109	0108	Pack weight	Package weight that is weighed with the product but does not count towards the result
40110	0109		
40215	0214	Total lot	Quantitative production inspection weight total production; 0 ~ 999999pcs
40216	0215		
40217	0216	Qualified lot	Quantitative production of qualified products; 0 ~ 999999pcs
40218	0217		
40279	0279	Photoelectric dusting cycle	Initial value: 60, range: 60 to 1800
40280	0280		
40281	0281	Photoelectric dust removal time	Initial value: 1, range: 1 to 10
40282	0282		
Statistics (Support function code 0x03)			
40501	0500	Qualifying cumulative count	
40502	0501		

40503	0502	Qualified cumulative weight	
40504	0503		
40505	0504	Cumulative number of out-of-bounds	
40506	0505		
40507	0506	Out of tolerance accumulated weight	
40508	0507		
40509	0508	Cumulative number of oves	
40510	0509		
40511	0510	Accumulated weight of underweight	
40512	0511		
40513	0512	Cumulative number of disqualifications	
40514	0513		
40515	0514	Disqualified accumulated weight	
40516	0515		
40517	0516	Total cumulative times	
40518	0817		
40519	0518	Total accumulated weight	
40520	0519		
40521	0520	Maximum	
40522	0521		
40523	0522	Minimum	
40524	0523		
40527	0526	Pass rate	
40528	0527		
40529	0528		

40530	0529	All qualified products are heavy	
40531	0530	Average weight of out-of-tolerance products	
40532	0531		
40533	0532	Underweight products average weight	
40534	0533		
40537	0536	Total cumulative average weight	
40538	0537		
40559	0558	Check weight result reading identifier (0, 1 change)	When the read value changes from 0 to 1, or from 1 to 0, the proof read value is updated data. (When power-on, the value is fixed at 3, stop and alarm is 2. When HMI programming, according to the change of value jump collection, attention should be paid to adding the judgment that is not equal to 2 or 3)
40560	0559		
40561	0560	Weight check result	Read as the result value of this test weight, when there is a new test result, the value will be updated.
40562	0561		
The following is readable bit status (read function code 0x01, write function code 0x05)			
00001	0000	Weight positive overflow	
00003	0002	Weight negative overflow	
00005	0004	Weight plus and minus sign	
00006	0005	Zero mark	
00007	0006	Stable sign	

00008	0007	Keep signs
00011	0010	Qualifying mark
00012	0011	Underage sign
00013	0012	Out-of-tolerance sign
00014	0013	busy
00015	0014	Call the police
00016	0015	Batch times to
00031	0030	Run (when writing ON, start running, stop running when writing OFF)
00032	0031	Zero clear (when writing ON, zero clear)
00033	0032	Clear alarm (Clear alarm when there is an alarm written ON)
00034	0033	Print (when writing ON, print out)

7.3 Print content

1. When the communication mode is set to print, connect the printer, click the print button on the "Statistics" interface, or send the print command through the communication mode, the output will be as follows:

-----	上分隔横线符
DATE: 2015.10.15	打印日期
TIME: 15:21	打印时间
PRODUCT CODE: 1	产品号
TARE WT: 0.000kg	皮重值
UP LIM: 0.030kg	超差值
REF WT: 8.135kg	目标值
LOW LIM: 0.030kg	欠差值
PASS CT: 1	合格累计次数
PASS WT: 8.140kg	合格累计重量
PASS AVR: 8.140kg	合格平均重量
PASS RATE: 100.00%	合格率
OVER CT: 0	超差累计次数
OVER WT: 0.000kg	超差累计重量
UNDER CT: 0	欠差累计次数
UNDER WT: 0.000kg	欠差累计重量
TOTAL CT: 1	总累计次数
TOTAL WT: 8.140kg	总累计重量
MIN WT: 8.140kg	最小值
MAX WT: 8.140kg	最大值
-----	上分隔横线符

2. When the communication mode is set to result printing, the device will actively send data. After each check, it will actively send the content shown in the following figure through the serial port:

20140503142100 0.0346kg

The format is timestamp+weight. If there is an external printing device, the above content will be printed. The above content is only an example. The specific printed data is subject to the actual test results.

3. The data format of CHRE mode is as follows:

S	leave	status	Leave	sign	limit	leave	Sampling	unit	CRC	CR	LF
T	a		a			a	results				
X	blank space		blank space			blank space					

Among:

(1) STX —— Start character, (02H) .

(2) status ——3 bit, In case of alarm, state 1 is "E" (45H), state 2 and state 3 are error identifications, otherwise all three bits are spaces 20H.

(3) sign —— 1 bit. Each time there is a new sampling mean, the data mark is added by 1, from 30H to 39H, and then back to 31H. Used for auxiliary extraction of sampling data.

(4) limit —— 1 bit is the limit of the current sampling value. The upper limit of the sampling value is "H" (48H). If the sampling value is qualified, it is "G" (47H). If the lower limit of the sampling value is "L" (4CH).

(5) Sampling results —— 7-digit weight data (including 6-digit content, 1-digit decimal point (2EH), if there is no decimal point, the high digit is 20H).If the weight value is 3.75, it is 30H 30H 30H 33H 2EH 37H 35H.

(7) Unit - 2 digits, "kg (6BH 67H)" for kilogram and "g (67H 20H)" for gram.

(8) CRC - is a checksum, which means that all preceding values are added and converted to decimal, and then the last two digits are taken and converted to ASCII code.

(9) CR - return sign (0DH).

(10) LF -- Line feed sign (0AH).

7.4 Set the parameters of the driver

1. Use a digital operator to set the input motor driver, weight check motor driver, and reject motor driver parameters F5.03 to 1, 2, and 3, respectively.
2. If the motor reverses after operation, use a digital operator to modify parameter F1.01 to 0.

8. Program upgrade

The device can upgrade the motherboard program and touch screen program through the way of U disk. For details, please refer to "Operation Instructions on Buttons and Operation Frames" in section 3.3.2.

System Setting		2021-10-26 11:02:39		Reserved >	
Device Model	CW-600G-101B >	Cal Para. Reset	I/O Define Reset		
Work Model	Check Model >				
Language	ENG[ENG]	Product Para. Reset	Work Para. Reset		
HMI Version: 00.01.05 Time: 2021/08/02 08:00:30 MainBoard Version: 0.00.00 Time: 2021/08/02 08:00:30 Mainboard Upgrade With U-disk					
		Communication parameter reset	Belt Para. Reset		
		All Para. Reset	Setting Date/Time		
Work Para.	I/O	Static Weight Calibration	Belt Speed Calibration	System Info.	EXIT

Figure 8-1 System Information screen example

After contacting our technical department, confirm that it is necessary to upgrade the program of the motherboard or touch screen. Obtain the corresponding program upgrade package first. Insert the USB flash drive with the upgrade package, click the "USB flash Drive Upgrade Controller" button to enter the upgrade interface, and perform the corresponding program upgrade according to the interface instructions. It is suggested to upgrade the program of the equipment under the guidance of our technical personnel, so as to avoid equipment failure or damage.

9. Metal Detection Guide

9.1 Introduction to Metal Detection

Metal detector is to use an electromagnetic field to check on a conveyor belt conveying to be inspected product, when detected metal signal more than the set value, Mixed metal alarm signal output or make removing means action.

9.2 Operating instructions



Note To prevent damage to the protective film, Please do not use sharp things to keys.

<u>LCD display</u>	Display Variety,Name, Judgement result, Operation mode,etc.
<u>Arrow key</u>	For project selection and switch the screen.
<u>Cancel key</u>	End existing screen, return to the previous page.
<u>Menu key</u>	In the basic screen, press this button, the screen changes to the menu, you can select menu;
<u>Product key</u>	In the basic screen, press it into a variety list screen, you can change a variety.
<u>Enter key</u>	Use in determining the project or setting.
<u>Run key</u>	Press this button, the conveyor belt starts running.
<u>Stop key</u>	Press this button, the belt is stopped.

9.3 The basic method of use

Press the power switch, the device is powered on, display the basic screen.



Basic Screen

Note: Since the machine uses dual channel detection, In the basic screen, X and Y represent two channel signals, cursor bar indicates the strength of the two channel signals; Figure above '5' and '3' represent the specific values of the signal strength of two channel .When the value of which is greater than 50, will alarm stop.

9.3.1 Registration of new products

Registration of new products including the product number, product name, sensitivity, gain, NG stop, reject delay time, reject hold time and phase settings.

9.3.1.1 Product number

From the basic screen, press the [product] key, the screen display products.

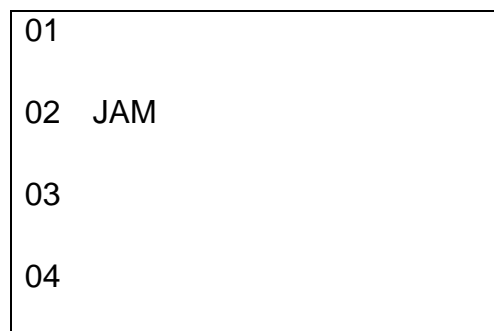

If you select [01], press the [ENTER] key to register the serial number, and then return to the basic screen.

9.3.1.2 Product name(Manual settings required)

From the basic screen, press the [Menu] key to enter the menu screen, move the cursor to the product parameters and then press the [ENTER] key to enter the product parameter screen, set the basic parameters for product.

1	Product Name
2	Sensitivity
3	Gain

From product parameter screen, press [^], [V] keys to move the cursor to the product name, press the [ENTER] key to enter the setting screen.

Prod-01:	
A B C D E F G H I	
J K L M N O P Q R S	Del.
T U V W X Y Z a b c	Ent.

Press the arrow keys to position the cursor at the character, press the [ENTER] key to enter the character.

After entering the name, press the arrow keys to align the cursor with [Ent.] position, press the [ENTER] key to register the name, automatically return to the parameter screen.

9.3.1.3 Sensitivity

From product parameter screen, press [\wedge], [\vee] keys to move the cursor to the sensitivity, press the [ENTER] key to enter the sensitivity setting screen.

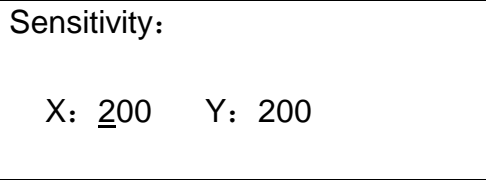

Sensitivity:
X: 200 Y: 200

Press [<], [>] key to move the cursor to the position to be adjusted; press [\wedge], [\vee] key, adjust the value on the cursor position. After the sensitivity adjustment is complete, press the [ENTER] key to save sensitivity parameters and return to the product parameter screen.

Note: Sensitivity value, after the auto setting usually do not need to make adjustments, but can be adjusted according to the actual situation.

9.3.1.4 Gain setting

From product parameter screen, press [\wedge], [\vee] keys to move the cursor to the Gain, press the [ENTER] key to enter the Gain setting screen.



Gain:
4

Press [<], [>] key to adjust gain level. After the gain adjustment is complete, press the [ENTER] key to save gain parameter and return to the product parameter screen.

Note: Gain level from 1 to 4, this parameter is automatically set by the system after auto-set, no need to adjust.

9.3.1.5 Reject delay time

From product parameter screen, press [\wedge], [\vee] keys to move the cursor to the RJ delay time, press the [ENTER] key to enter the RJ delay time screen. The factory settings are already in place, please do not modify them without authorization.

RJ Delay Time:

0.500 S

Press [\leftarrow], [\rightarrow] key to move the cursor to the position to be adjusted; press [\wedge], [\vee] key, adjust the value on the cursor position. After the RJ Delay Time adjustment is complete, press the [ENTER] key to save sensitivity parameters and return to the product parameter screen.

Note: RJ delay time means after being detected by the metal foreign body begins to reject the action this time. The factory settings are already in place, please do not modify them without authorization.

9.3.1.6 Reject hold time (Manual settings required)

From product parameter screen, press [\wedge], [\vee] keys to move the cursor to the RJ hole time, press the [ENTER] key to enter the RJ hole time screen.

RJ Hold Time:

0.500 S

Press [\leftarrow], [\rightarrow] key to move the cursor to the position to be adjusted; press [\wedge], [\vee] key, adjust the value on the cursor position. After the RJ Hole Time adjustment is complete, press the [ENTER] key to save sensitivity parameters and return to the product parameter screen.

Note: RJ hole time means rejector start work until the end of the action this time. This time needs to be set based on the current detection speed, $T=S/V$, $S=2 * \text{detection distance threshold}$, and V is the detection belt line speed (whichever is actual).

9.3.1.7 Phototube

If from the [Product Parameters] screen, press the [Up] \wedge , [Down] \vee keys to move the cursor to [Phototube], and press the [OK] key to enter the Phototube adjustment screen. If allowed, it means to enable the photoelectric detection function, and if prohibited, it means to disable the photoelectric detection function. The factory default setting is allowed, please do not modify it without authorization.

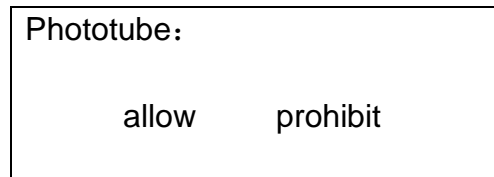

9.3.1.8 Detection time (manual setting required)

If you press the [Up] and [Down] keys from the [Product Parameters] screen, move the cursor to [Detection Time], and press the [Confirm] key to enter the detection time adjustment screen.

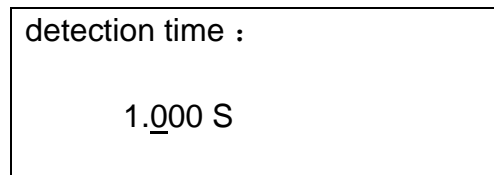

Press the [Left]<, [Right]>keys to move the cursor to the position of the number to be adjusted; Press the [Up] and [Down] keys to adjust the number on the cursor position. After the detection time adjustment is completed, press the [Confirm] key to save the rejection hold time parameter and return to the [Product Parameters] screen.

Note: This time needs to be set based on the current detection speed, $T=S/V$, S is the length of the metal detection machine (standard is 0.3m), and V is the detection belt line speed (based on the actual situation).

9.3.1.9 Phase setting

From product parameter screen, press [\wedge], [\vee] keys to move the cursor to the Phase, press the [ENTER] key to enter the phase screen.

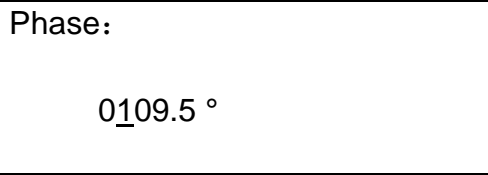

Phase:
0109.5 °

Press [$<$], [$>$] key to move the cursor to the position to be adjusted; press [\wedge], [\vee] key, adjust the value on the cursor position. After the phase adjustment is complete, press the [ENTER] key to save phase parameters and return to the product parameter screen.

Note: The phase, after the automatic setting does not need to make adjustments.

9.3.2 Auto-set (All automatic execution)

Ready the testing product (Hereinafter referred to as the standard workpiece), the standard workpiece should be able to reflect the average characteristics of the inspected product (size, weight, ingredients and packaging).

In the basic screen, press the [MENU] key to enter the menu screen. press [\wedge], [\vee] keys to move the cursor to the Auto-set, press the [ENTER] key to enter the auto-set screen.



Prod-01
Wait...

After a few seconds, the display prompts [Put in the product].

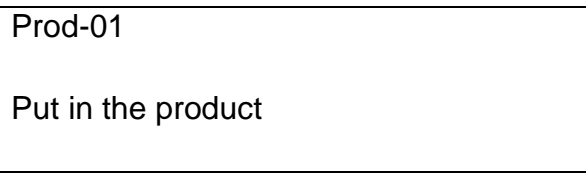

Prod-01
Put in the product

he operator put in the standard workpiece, after a few seconds, the display prompts [Auto-set over.], Press the [ENTER] key to return to the menu screen, Auto setup is complete.

9.3.3 Choose product

From the basic screen, press the [product] key to enter the product selection screen.

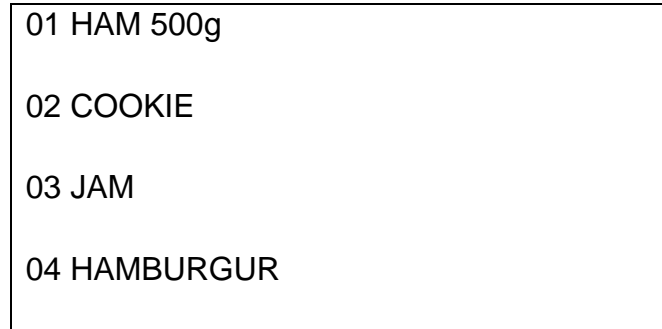

press [^], [v] keys to move the cursor to the corresponding product, press the [ENTER] key. Product selection is completed.

9.3.4 Run & Stop

Run:

To ensure stable operation of the metal detection machine, please wait for more than 10 minutes after turning on the power before starting operation. Before starting operation, remove the inspected items from the metal detection conveyor belt and the front conveyor belt before starting the conveyor. Press the [Start] button, as the conveyor belt has just started for about 1 second and is waiting for the action to stabilize, the metal detection machine will not operate. Moreover, if there is a variety change during the operation of the conveyor belt, there will be about 10 seconds before the metal detection machine will not operate.

Stop:

Press the [Stop] key. The conveyor belt stops and enters a stop state.

Note: Both operation and startup are controlled through the touch screen, and there is no need to operate on the metal detection control panel.

9.3.5 Confirm detection sensitivity

Use qualified and unqualified samples to confirm whether they can be tested correctly.

Introduction to qualified and unqualified samples

decision procedure	Qualified samples	Unqualified samples
Metal mixing inspection	It is known that there is no metal mixed in the inspected product	Foreign object samples (or test pieces) with qualified samples as the management benchmark in the inspected product
Missing parts inspection	Among the inspected items, there are objects that are intended to be inspected for missing parts	In the inspected products, there is a lack of objects to be inspected for missing parts

Methods and precautions for action confirmation

decision procedure	Method of action confirmation	Select action (when connected to the culler)
Metal mixing inspection	Use the action confirmation function to confirm the detection sensitivity.	Not related to the judgment result
Missing parts inspection	Confirm the detection sensitivity while watching the screen display.	Perform actions based on the judgment results.

Confirm the detection sensitivity while watching the screen display.

Transfer qualified and unqualified samples, and confirm the detection sensitivity based on the numerical values displayed on the screen.

When the result of action confirmation is that the action cannot be performed correctly

When the result of confirming the metal detection machine's action (detection sensitivity) is that it cannot operate correctly, please take the following measures.

Perform automatic settings.

Confirm sensitivity.

9.3.6 Routine Maintenance

Daily inspection items

(1) Please check the following before operation

- Presence of contact area
- Confirm that the detection sensitivity

(2) After the job, need to clean up the conveyor belt.

Cleaning precautions

1. When cleaning, the power plug must be unplugged.
2. Cleaning tools such as soft plastic brushes or cloth should be used. Do not use metal brushes, etc.
3. Clean with neutral detergent. Do not use diluents or organic solvents such as benzene.

10. Size

When the equipment is installed on site, it is necessary to ensure that there is no contact between the weighing table and the surrounding area to avoid affecting the normal weighing. The distance between the surrounding area of the weighing table should be greater than 10mm.

10.1 Outline size drawing (unit: mm)

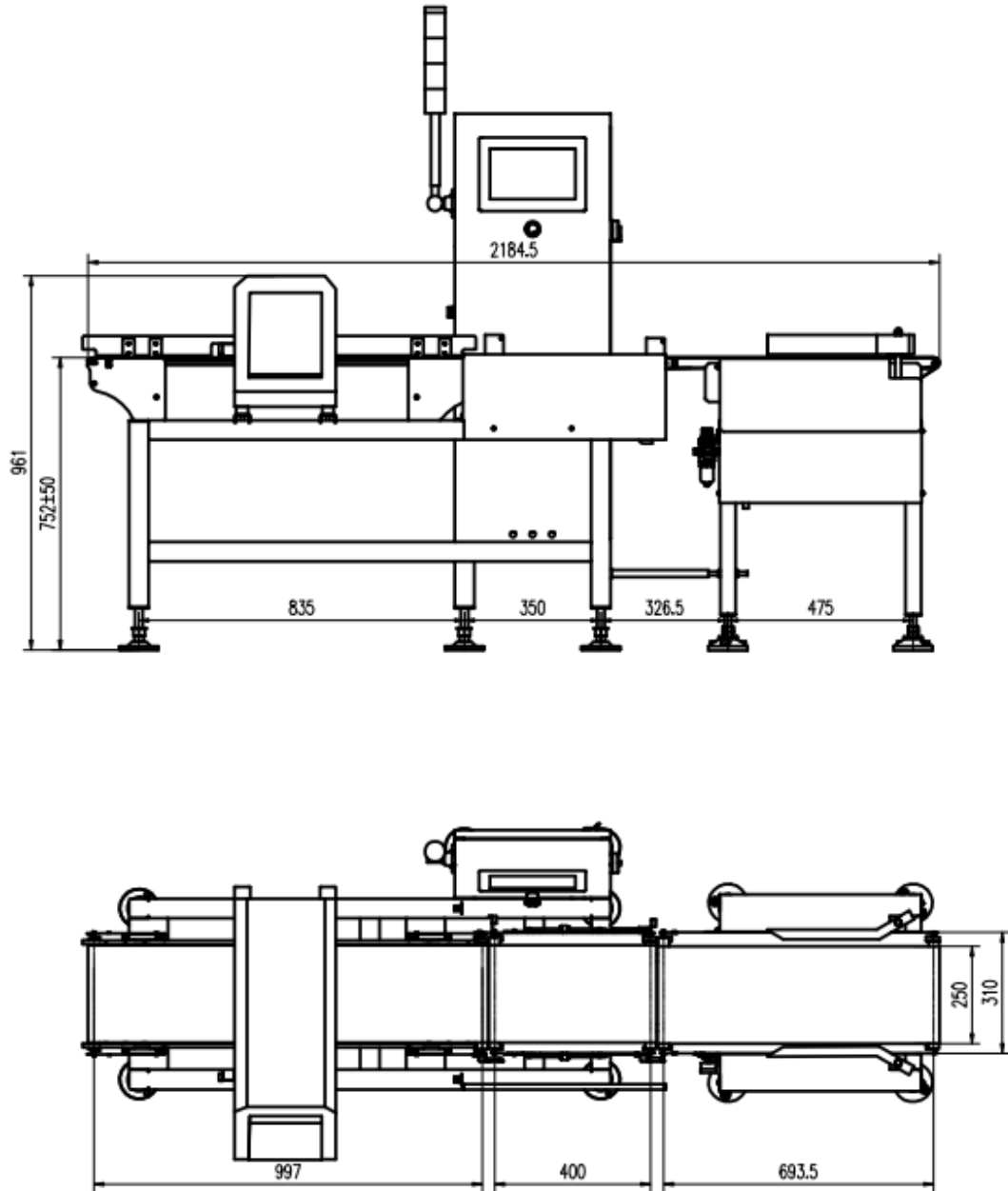

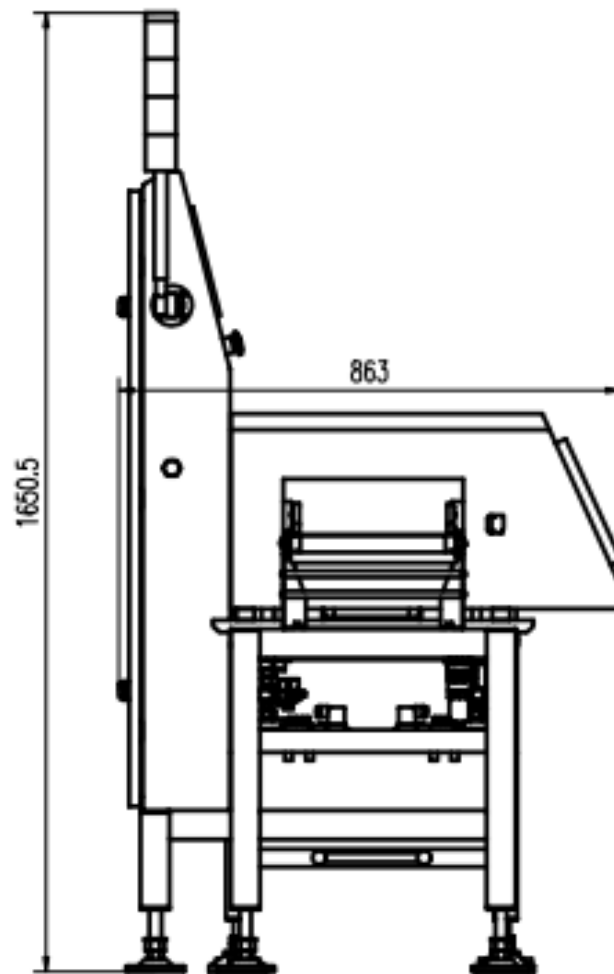

*** Note: The width, length and height of the scale stand of non-standard customized products may be different from that of the standard products. For details, please refer to the technical documents or drawings confirmed by the user.**

11. Equipment repair and maintenance

11.1 Maintenance of motors

11.1.1 Routine maintenance

- Keep the motor clean and prevent oil, water and other dirt from entering the motor.
- Check motor terminal bolts and motor base fixing bolts for loosening
- Check the rotation of the motor blades
- Check whether the bearings at both ends of the motor have oil leakage and other phenomena
- Pay attention to observe whether there is abnormal noise, vibration and special smell in the operation of the motor.

11.1.2 Regular maintenance

- For normal operation of the motor, the mechanic and maintenance electrician shall carry out the maintenance once a year.
- Remove dust or debris inside the motor (be careful not to damage the winding of the motor)
- Check whether the rotor of the motor is flexible and replace the wearing parts (bearings, etc.)
- Check the insulation resistance of the motor windings to the ground. When the insulation resistance is below $0.5M\Omega$, the motor must be dried.
- Replace the grease.
- Check whether the no-load current is within the specified range

11.1.3 Precautions

- In the process of maintenance, attention should be paid to the safety of electricity and mechanical transmission, and illegal operation is strictly prohibited.
- When installing the repaired or replaced motor, attention should be paid to the wiring mode, and attention should be paid to whether the motor rotation direction is consistent with the reality.
- After installation, the motor should be clicked, and pay attention to observe whether the motor runs normally.

11.2 Check the failure cause and treatment method of weight scale

11.2.1 No display on the touch screen

- Method of Handling poor Power contact Connect the power cable
- Loose or falling data cable treatment method Connect the data cable

11.2.2 Data pulsation large, abnormal fluctuation

- Handling Method for loose screws of the heavy machine pedestal Tighten the screws of the heavy machine pedestal

- The sensor is obviously disturbed, such as air conditioning, air flow, etc. Disposal method to get rid of external interference
- Ground shaking, vibration, such as nearby machine rotation interference, cars passing by, etc. Treatment methods to get rid of external interference
- The conveyer belt is affected by viscous objects
- Sensor base has debris accumulation or stuck processing method to get rid of external interference
- Filter coefficient set too small processing method to increase the filter coefficient

11.2.3 The display is always zero

- The object is light and the weight falls in the zero range. The treatment should be resolved by resetting the "zero range".
- Device trace to zero. The handling method can be solved by adjusting the "automatic zero tracking" item in the calibration option of the system.
- The sensor data cable is loose, and the contact is not good. Solution Connect the sensor data cable properly

11.2.4 Abnormal data display

- The error is too large. Handling Method Recalibrate the scale.
- Product number selection error. The handling method should be resolved by clicking "Switch Product" again and selecting the corresponding companion product number.
- The ambient temperature exceeds the normal operating range of the sensor. Ensure that the ambient temperature is normal
- Aging or deformation of sensor components. Solution Replace the sensor

11.2.5 Busy alarm

- After the object into the material is not out of the weighing platform, and there are objects on the weighing platform. Handling Method Adjust the feeding speed, the material out of the weighing platform before allowing the next material on the weighing platform.

11.2.6 Packaging error

- Remove too many unqualified products in time. Handling method Eliminate unqualified products in time.

11.2.7 Continuous nonconformity alarm

- The number of consecutive disqualifications exceeding the set value. Alarm prompt, no need to deal with the weight check work normally.

11.2.8 Excess plugging time

- During operation, the object stays too long at the feeding or discharging end. Solution Check the reason for the object staying time is too long and deal with it in time.

11.2.9 Below the minimum sampling time

- The object is coming off the scale too quickly in operation. Adjust the speed of the belt of the weighing table within the detectable range.

11.2.10 Super maximum sampling time

- Long period of time when the object in operation is not off the scale. Check the reason why the object is not out of the weighing table for a long time and deal with it in time.

11.2.11 Overload motor load limit

- The weight of the object exceeds the maximum range by a certain amount (exceeds the maximum weight of the motor). Handling Methods Do not weigh objects beyond the maximum range.

11.2.12 Automatic zeroing failed

- 1. The current weight is out of the zero clearance range.
- 2. The scale is unstable. Treatment Method 1 Empty the scale table 2 Make sure the scale is stable